

IA261/262 Hardware User's Manual

Fourth Edition, December 2009

www.moxa.com/product

MOXA[®]

© 2009 Moxa Inc. All rights reserved.
Reproduction without permission is prohibited.

IA261/262 Hardware User's Manual

The software described in this manual is furnished under a license agreement and may be used only in accordance with the terms of that agreement.

Copyright Notice

Copyright © 2009 Moxa Inc.
All rights reserved.
Reproduction without permission is prohibited.

Trademarks

MOXA is a registered trademark of Moxa Inc.
All other trademarks or registered marks in this manual belong to their respective manufacturers.

Disclaimer

Information in this document is subject to change without notice and does not represent a commitment on the part of Moxa.

Moxa provides this document “as is,” without warranty of any kind, either expressed or implied, including, but not limited to, its particular purpose. Moxa reserves the right to make improvements and/or changes to this manual, or to the products and/or the programs described in this manual, at any time.

Information provided in this manual is intended to be accurate and reliable. However, Moxa assumes no responsibility for its use, or for any infringements on the rights of third parties that may result from its use.

This product might include unintentional technical or typographical errors. Changes are periodically made to the information herein to correct such errors, and these changes are incorporated into new editions of the publication.

Technical Support Contact Information

www.moxa.com/support

Moxa Americas:

Toll-free: 1-888-669-2872

Tel: +1-714-528-6777

Fax: +1-714-528-6778

Moxa China (Shanghai office):

Toll-free: 800-820-5036

Tel: +86-21-5258-9955

Fax: +86-10-6872-3958

Moxa Europe:

Tel: +49-89-3 70 03 99-0

Fax: +49-89-3 70 03 99-99

Moxa Asia-Pacific:

Tel: +886-2-8919-1230

Fax: +886-2-8919-1231

Table of Contents

Chapter 1	Introduction	1-1
	Overview	1-2
	Package Checklist	1-2
	Product Features	1-3
	Product Hardware Specifications.....	1-4
	Hardware Block Diagram	1-6
Chapter 2	Hardware Introduction.....	2-1
	Appearance	2-2
	Dimensions (unit = mm)	2-3
	LED Indicators.....	2-4
	Reset Button.....	2-4
	Real Time Clock	2-5
	Placement Options	2-5
	DIN-Rail Mounting	2-5
	Wall Mounting (optional).....	2-6
Chapter 3	Hardware Connection Description	3-1
	Wiring Requirements	3-2
	Connecting the Power	3-2
	Grounding the Unit.....	3-3
	Connecting to the Console Port	3-4
	Connecting to a Display.....	3-4
	Connecting to a Keyboard and Mouse.....	3-5
	Connecting to the Network	3-5
	Connecting to a Serial Device.....	3-5
	Connecting to a CAN Device.....	3-6
	Connecting to the DI/DO	3-6
	Digital Input Wiring	3-7
	Digital Output Wiring	3-7
	Insert CompactFlash Card.....	3-7
	USB Hosts	3-9
Appendix A	Regulatory Approval Statements	A-1

Thank you for purchasing the Moxa IA261/262 RISC-based industrial ready-to-run embedded computer. This product's features include four RS-232/422/485 serial ports (2 ports for IA262), dual 10/100 Mbps Ethernet ports, 8 digital input channels and 8 digital output channels, VGA output, a CompactFlash socket for mass storage expansion, and USB ports for keyboard/mouse connection or mass storage disk expansion, IA262 also supports dual CAN ports for industrial automation devices connection. These features make the IA261/262 series ideal for your embedded applications, especially the environment in industrial environment such as SCADA, manufacturing automation and other industrial applications.

This manual introduces the hardware of the IA261/262 series embedded computers. After a brief introduction of the hardware features, the manual focuses on installation and hardware configuration with device interfaces.

The following topics are covered in this chapter:

- Overview**
- Package Checklist**
- Product Features**
- Product Hardware Specifications**
- Hardware Block Diagram**

Overview

The IA261/IA262 embedded computers, which are ideal for industrial automation applications, feature 4 RS-232/422/485 serial ports (2 for IA262), dual CAN ports (IA262 only), dual Ethernet ports, 8 digital input channels, 8 digital output channels, VGA output, 2 USB hosts and a CompactFlash socket in a compact, industrial-strength aluminum rugged casing. The DIN-Rail vertical form factor makes the IA261/262 a cost effective solution for installation in small cabinets. This space-saving solution also facilitates easy wiring, and is the best choice of front-end embedded controller for industrial applications.

Due to its VGA output capability, IA261/262 is not only play the role of protocol conversion or data acquisition for the field site devices, it is also suitable for SCADA system in industrial applications such as manufacturing automation, production line process monitoring, mining automation etc to be the operator interface terminal at the field site with VGA monitor and proper HMI software.

The diversified peripherals, which include RS-232/422/485, CANbus, digital input and digital output, are all designed for industrial environments. The embedded 2 KV isolation protection for serial signals and CANbus ports, and enhanced 3 KV protection for digital I/O, make the IA261/262 the most reliable solution of this type for harsh, industrial environments. Since the dual LAN ports are built, the IA261/262 is an ideal communication platform for Network Redundant applications.

In addition to the standard model, the IA261/IA262 also comes in wide temperature models. The IA261-T and IA262-T have an operating temperature range of -40 to 75°C, and are appropriate for harsh industrial automation environments. The industrial mechanism of the IA261/IA262 design provides robust, reliable computing. Due to the RISC-based architecture, the IA261/IA262 will not generate too much heat while being used. The high communication performance and fanless design make the IA261/IA262 ideal for industrial automation environments.

The IA261/262 embedded computers use a Cirrus Logic EP9315 ARM9, 32-bit, 200 MHz RISC CPU. Unlike the X86 CPU, which uses a CISC design, the RISC design architecture and modern semiconductor technology provide the IA261/262 with a powerful computing engine and communication functions, but without generating a lot of heat. The built-in 32 MB NOR Flash ROM and 128 MB SDRAM give you enough memory to run your application software directly on the IA261/262.

The IA261/262 runs Linux or WinCE 6.0 (pre-installed), providing a friendly environment for developing sophisticated application software. Moxa's quality software support makes programming and developing bug-free code easier, quicker, and less expensive.

Package Checklist

The IA261/262 Series includes the following models:

IA261-I-CE

RISC-based Embedded Computer with VGA, 4 Serial Ports, Dual LANs, DIO, CompactFlash, USB, WinCE 6.0, isolation protection for all IO

IA261-I-T-CE

RISC-based Embedded Computer with VGA, 4 Serial Ports, Dual LANs, DIO, CompactFlash, USB, WinCE 6.0, Wide Temperature, isolation protection for all IO

IA262-I-CE

RISC-based Embedded Computer with VGA, 2 Serial Ports, Dual LANs, CAN, DIO, CompactFlash, USB, WinCE 6.0, isolation protection for all IO

IA262-I-T-CE

RISC-based Embedded Computer with VGA, 2 Serial Ports, Dual LANs, CAN, DIO, CompactFlash, USB, WinCE 6.0, Wide Temperature, isolation protection for all IO

IA261-I-LX

RISC-based Embedded Computer with VGA, 4 Serial Ports, Dual LANs, DIO, CompactFlash, USB, Linux, isolation protection for all IO

IA261-I-T-LX

RISC-based Embedded Computer with VGA, 4 Serial Ports, Dual LANs, DIO, CompactFlash, USB, Linux, Wide Temperature, isolation protection for all IO

IA262-I-LX

RISC-based Embedded Computer with VGA, 2 Serial Ports, Dual LANs, CAN, DIO, CompactFlash, USB, Linux, isolation protection for all IO

IA262-I-T-LX

RISC-based Embedded Computer with VGA, 2 Serial Ports, Dual LANs, CAN, DIO, CompactFlash, USB, Linux, Wide Temperature, isolation protection for all IO

All models of the IA261/262 series are shipped with the following items:

- 1 IA261/262 Embedded Computer
- Wall-Mounting Kit
- DIN-Rail Mounting Kit (attach to the product's casing)
- Quick Installation Guide
- Document & Software CD
- Ethernet Cable: RJ45 to RJ45 cross-over cable, 100 cm
- CBL-4PINDB9F-100: 4-pin header to DB9 female console port cable, 100 cm
- Universal Power Adapter
- Product Warranty Statement

NOTE: *Notify your sales representative if any of the above items are missing or damaged.*

Product Features

- Cirrus Logic EP9315 ARM9 CPU, 200 MHz
- 128 MB RAM on-board, 32 MB Flash Disk
- VGA interface for field site monitoring
- 2KV digitally isolated RS-232/422/485 serial ports
- Dual 10/100 Mbps Ethernet for network redundancy
- Dual 2KV optically isolated CAN ports with CANopen protocol support
- 8+8 DI/DO with 3KV optical isolation protection
- 12 to 48VDC redundant power input design
- Support CF socket and USB 2.0 Host
- Ready-to-Run WinCE 6.0 or Linux platform
- -40 ~ 75°C wide temperature model is available

Product Hardware Specifications

System

CPU:	Cirrus Logic EP9315 ARM9 CPU, 200 MHz
DRAM:	128 MB onboard
Flash:	32 MB Flash onboard
Storage Expansion:	CompactFlash socket x 1 for storage expansion
USB:	USB Host x 2 compliant to USB 2.0 (OHCI), Type A connector
Console/Debugging Port:	RS-232 x 1 (TxD, RxD, GND), 4-pin header output
Others:	RTC, buzzer, Watchdog Timer, Reset button
OS:	built-in WinCE 6.0 or Linux

Display

Graphical controller:	EP9315 internal graphics accelerator engine with TTL graphical signal support
Display Memory:	Dynamic video memory, share system memory
Graphical Resolution:	1024 x 768 (8-bit), 800 x 600 (16-bit), 640 x 480 (24-bit)
Display Interface:	CRT interface for VGA output, DB15 female connector

Network Communication

LAN:	Auto-sensing 10/100Mbps x 2, RJ45
Protection:	built-in 1.5KV magnetic isolation protection

Serial Communicaiton

Serial Port:	IA261: RS-232/422/485 x 4, software-selectable IA262: RS-232/422/485 x 2, software-selectable RS-232 signals: TxD, RxD, DTR, DSR, RTS, CTS, DCD, GND RS-422 signals: TxD+, TxD-, RxD+, RxD-, GND 4-wire RS-485 signals: TxD+, TxD-, RxD+, RxD-, GND 2-wire RS-485 signals: Data+, Data-, GND
Protection:	built-in 15KV ESD protection for all signals, 2KV digital isolation protection
Data bits:	5, 6, 7, 8
Stop bits:	1, 1.5, 2
Parity:	None, Even, Odd, Space, Mark
Flow Control:	RTS/CTS, XON/XOFF, RS-485 ADDC™
Speed:	50 bps to 921.6 Kbps, supporting non-standard baudrates
Connector Type:	D-Sub male 9-pin connector

CAN Communication (IA262 only)

Interface:	Optically isolated CAN2.0A/2.0B compliant ports x 2
CAN Controller:	Phillips SJA1000T
Signal:	CAN-H, CAN-L
Protocol:	Support CANopen library
Protection:	2KV optical isolation protection
Speed:	10Kbps to 1Mbps
Connector Type:	D-Sub male 9-pin connector

Digital Input

Input Channels:	8, source type
-----------------	----------------

Digital input levels:	Dry contact: Logic level 0: Close to GND Logic level 1: Open Wet contact: Logic level 0: +3V max Logic level 1: +10V ~ +30V (COM to DI)
Protection:	3KV optical isolation protection
Connector Type:	10-Pin Screw Terminal Block (8 points / COM / GND)
Digital Output	
Output Channels:	8, sink type
On-state Voltage:	24 VDC nominal, open collector to 30 V
Output Current Rating:	Max. 200 mA per channel
Protection:	3KV optical isolation protection
Connector Type:	9-Pin Screw Terminal Block
LEDs	
System:	Power x 1, Ready x 1, Storage x 1
LAN:	10M/Link x 2 (on connector), 100M/Link x 2 (on connector)
Serial:	TxD x 4, RxD x 4 IA261: P1 ~ P4 for serial ports IA262: P1 ~ P2 for serial ports, P3 ~ P4 for CAN ports
Power Requirements	
Power Input:	Dual power input design PWR1: 12 to 48 VDC, power jack with thread PWR2: 12 to 48 VDC, 3-pin terminal block
Power Consumption:	783 mA @ 12 VDC without loading USB ports, 1.2A @ 12 VDC with loading 2 USB ports
Mechanical	
Outlook Shape:	Industrial vertical form factor
Dimensions (WxDxH):	60 x 115 x 152 mm (without din-rail kit or wall mount kit)
Gross Weight:	965 g
Construction Material:	Aluminum
Mounting:	DIN-rail, wall mounting
Environmental	
Operating Temperature:	-10 to 60°C (14 to 140°F) -40 to 75°C (-40 to 167°F) is optional for -T models
Storage Temperature:	-20 to 80°C (-4 to 176°F), 5 to 95% RH -40 to 85°C (-40 to 185°F) is optional for -T models
Anti-Vibration	5 g rms @ IEC-68-2-34, random wave, 5-500 Hz, 1 hr/axis
Anti-Shock	50 g @ IEC-68-2-27, half sine wave, 11 ms
Regulatory Approvals	
EMC:	FCC, CE (Class A)
Safety:	UL, cUL, LVD
Others:	RoHS, WEEE
Warranty:	5 years

Hardware Block Diagram

IA-261

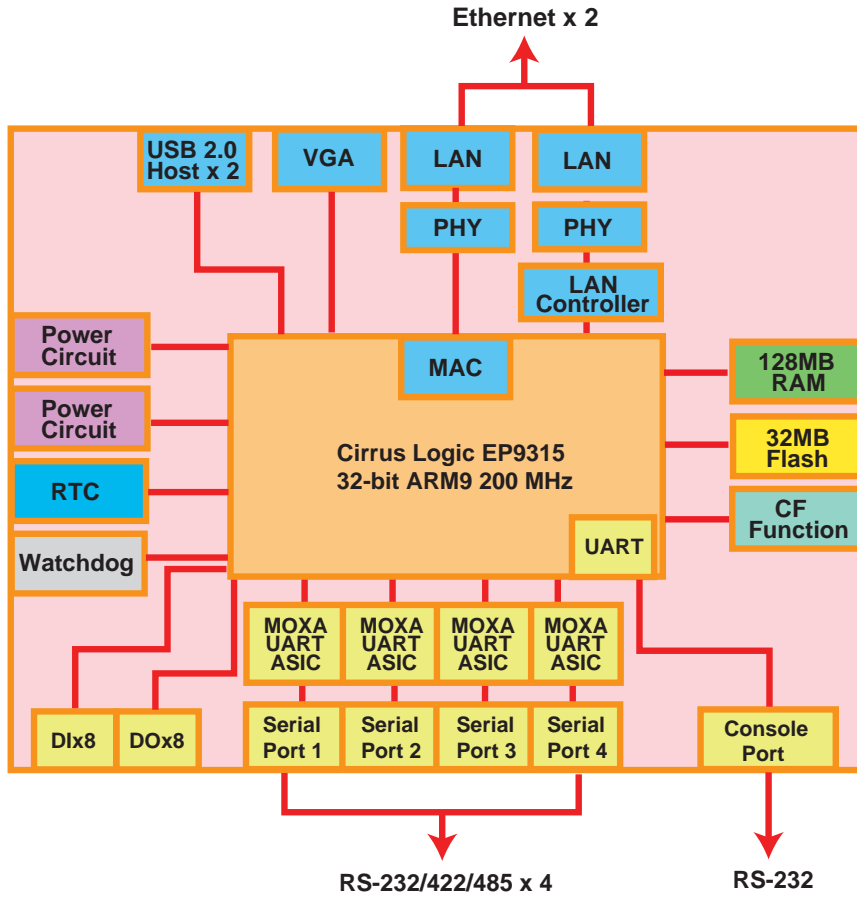

IA-262

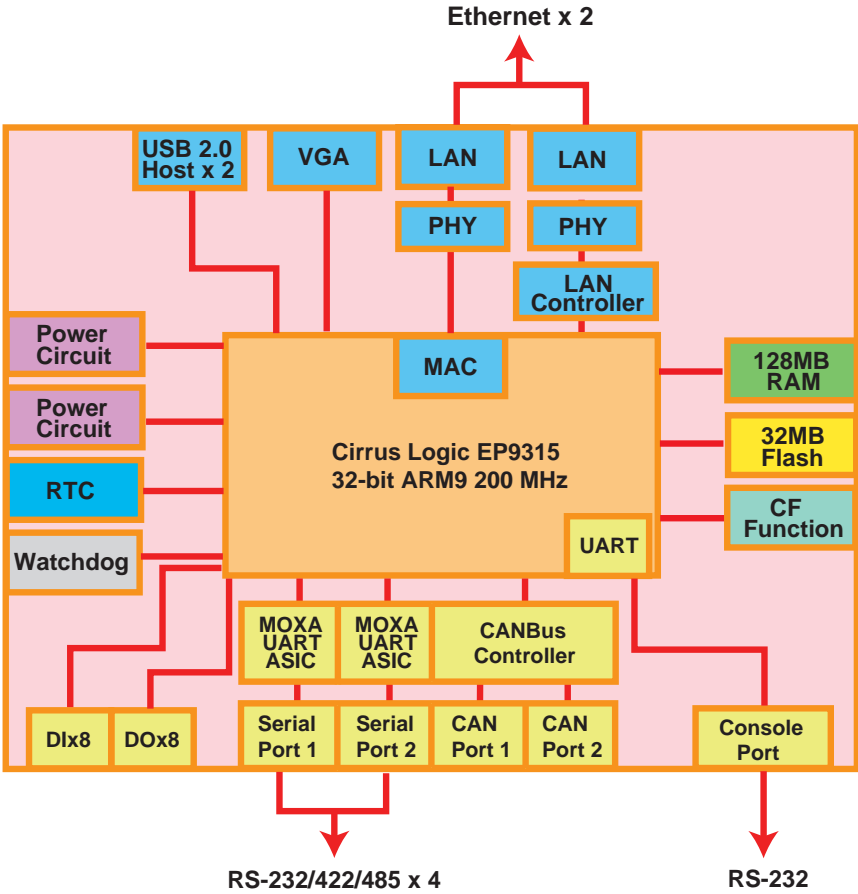

2

Hardware Introduction

The IA261/262 embedded computers are compact and rugged, making them suitable for industrial applications. The LED indicators allow users to monitor performance and identify trouble spots quickly, and the multiple ports can be used to connect a variety of devices. The IA261/262 comes with a reliable and stable hardware platform that lets you devote the bulk of your time to application development. In this chapter, we provide basic information about the embedded computer's hardware and its various components.

In this chapter, we cover the following topics:

- ❑ **Appearance**
- ❑ **Dimensions**
- ❑ **LED Indicators**
- ❑ **Reset Button**
- ❑ **Real Time Clock**
- ❑ **Placement Options**
 - DIN-Rail Mounting
 - Wall Mounting (optional)

Appearance

Top View

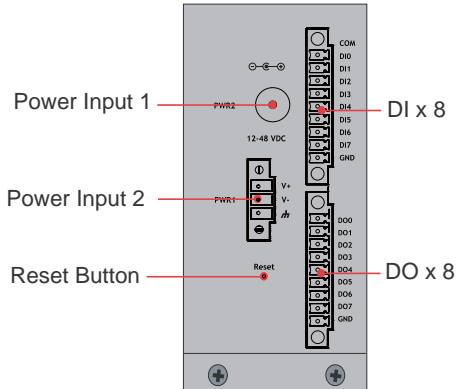

Front View

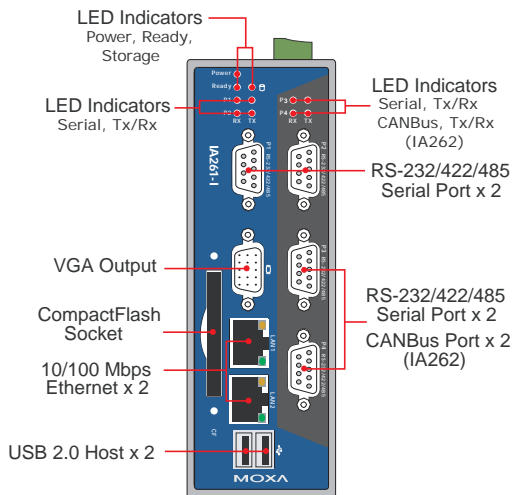

Rear View

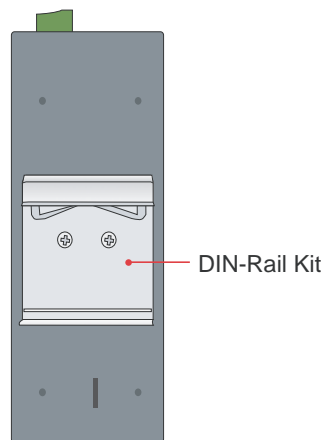

LED Indicators

The IA261/262 has 15 LED indicators on the front panel. Refer to the following table for information about each LED.

LED Name	Color	Meaning
Power	Green	Power is ON.
	Off	No power is being received, or power error exists.
Ready	Green	OS is ready and functioning normally (after booting up).
	Off	OS is not ready.
Storage	Green	Data is being written to or read from the storage unit.
	Off	Storage unit is idle.
LAN1, LAN2	Orange	10 Mbps Ethernet connection
	Green	100 Mbps Ethernet connection
P1-P4 (TX)	Green	Serial/CAN port is transmitting TX data to the serial device.
	Off	Serial/CAN port is not transmitting TX data to the serial device.
P1-P4 (RX)	Orange	Serial/CAN port is receiving RX data from the serial device.
	Off	Serial/CAN port is not receiving RX data to the serial device.

Reset Button

The IA261/262 has one reset button located on the top panel. This button can be used to do a simple **Reset**, which involves switching the power off and then switching the power back on again. The button can also be used to **Reset to default**, which returns the IA261/262 to its factory default parameter configuration.

Reset Function

Pressing the **Reset Button** then releasing it in one second initiates a hardware reboot. The button plays the same role as a desktop PC's reset button.

In normal use, you should NOT use the **Reset Button**. You should only use this function if the software is not working properly. To reset an embedded system, always use the software reboot command inside the OS to protect the integrity of data being transmitted or processed.

Reset to Default

Press and hold the **Reset Button** continuously for at least 5 seconds to load the **factory default configuration**. After the factory default configuration has been loaded, the system will reboot automatically. The **Ready** LED will blink on and off for the first 5 seconds, and then maintain a steady glow once the system has rebooted.

We recommend that you only use this function if the software is not working properly and you want to load factory default settings. The **Reset to Default** functionality is not designed to hard reboot the IA261/262.



ATTENTION

Reset to Default preserves user's data

The **Reset to Default** function will NOT format the user directory and erase the user's data. Using the Reset to default function will only load the configuration file. The rest of the user's data stored in the Flash ROM will remain intact.

Real Time Clock

The IA261/262's real time clock is powered by a lithium battery. We strongly recommend that you do not replace the lithium battery without help from a qualified Moxa support engineer. If you need to change the battery, contact the Moxa RMA service team.



WARNING

There is a risk of explosion if the battery is replaced by an incorrect type.

Placement Options

DIN-Rail Mounting

The aluminum DIN-Rail attachment plate is already attached to the product's casing. To attach the plate to IA261/262, make sure that the stiff metal spring is facing the top of the IA261/262, as shown in the following figures.

STEP1: Insert the top of the DIN-Rail into the slot just below the stiff metal spring.

STEP2: The DIN-Rail attachment unit will snap into place as shown.

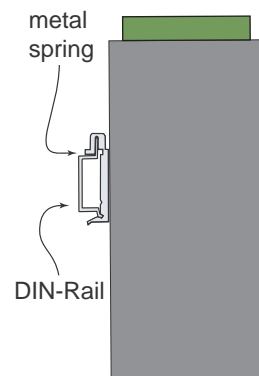
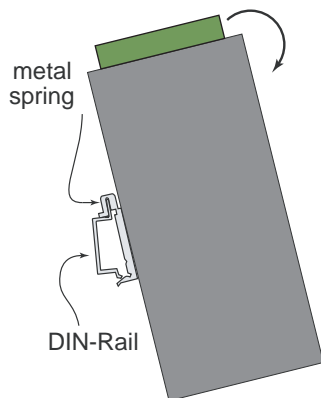

To remove the IA261/262 from the DIN-Rail, simply reverse Steps 1 and 2.

Wall Mounting (optional)

For some applications, you will find it convenient to mount the IA261/262 on the wall.

However, we strongly recommend that you use DIN-Rail mounting for the IA261/262 computer when installing at field sites that encounter high levels of vibration and shock.

The wall mounting procedure is illustrated below.

STEP 1:

Remove the aluminum DIN-Rail attachment plate from IA261/262's rear panel, and then attach the wall mount plates, as shown by the figures at the right.

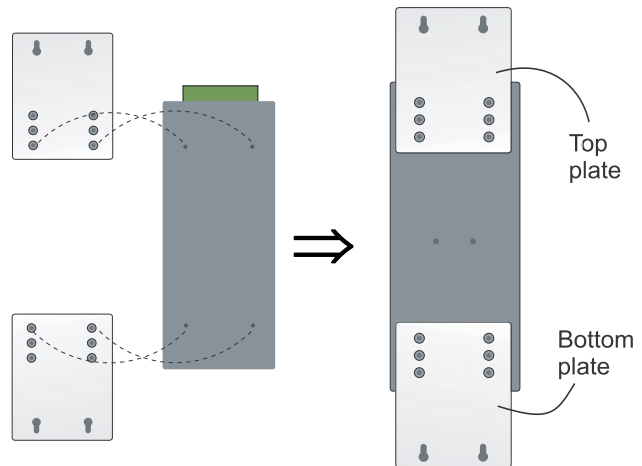

STEP 2:

Mounting IA261/262 on the wall requires 4 screws. Use the switch, with wall mount plates attached, as a guide to mark the correct locations of the 4 screws. The heads of the screws should be less than 6.0 mm in diameter, and the shafts should be less than 3.5 mm in diameter, as shown by the figure at the right.

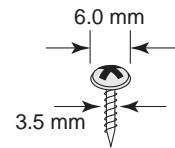

NOTE Before tightening the screws into the wall, make sure the screw head and shank size are suitable by inserting the screw into one of the keyhole-shaped apertures of the Wall Mounting Plates.

Do not screw the screws in completely—leave about 2 mm to allow room for sliding the wall mount panel between the wall and the screws.

STEP 3:

Once the screws are fixed on the wall, insert the four screw heads through the large parts of the keyhole-shaped apertures, and then slide IA261/262 downwards, as indicated. Tighten the four screws for added stability.

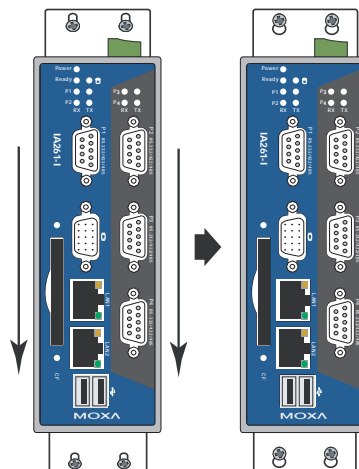

Hardware Connection Description

This section describes how to connect the IA261/262 to a network and various devices for first time testing purposes. We cover Wiring Requirements, Connecting the Power, Grounding the IA261/262, Connecting to the Network, Connecting to a Serial Device, Connecting to a CAN device, connecting to the Console Port, VGA, CompactFlash Socket, USB, and DI/DO.

The following topics are covered in this chapter:

- Wiring Requirements**
 - Connecting the Power
 - Grounding the Unit
- Connecting to the Console Port**
- Connecting to a Display**
- Connecting to a Keyboard and Mouse**
- Connecting to the Network**
- Connecting to a Serial Device**
- Connecting to a CAN Device**
- Connecting to the DI/DO**
- Insert CompactFlash Card**
- USB Hosts**

Wiring Requirements

In this section, we describe how to connect various devices to the embedded computer. You should heed the following common safety precautions before proceeding with the installation of any electronic device:

- Use separate paths to route wiring for power and devices. If power wiring and device wiring paths must cross, make sure the wires are perpendicular at the intersection point.

NOTE: Do not run signal or communication wiring and power wiring in the same wire conduit. To avoid interference, wires with different signal characteristics should be routed separately.

- You can use the type of signal transmitted through a wire to determine which wires should be kept separate. The rule of thumb is that wiring that shares similar electrical characteristics can be bundled together.
- Keep input wiring and output wiring separate.
- When necessary, it is strongly advised that you label wiring to all devices in the system.



ATTENTION

Safety First!

Be sure to disconnect the power cord before installing and/or wiring.

Electrical Current Caution!

Calculate the maximum possible current in each power wire and common wire. Observe all electrical codes dictating the maximum current allowable for each wire size.

If the current goes above the maximum ratings, the wiring could overheat, causing serious damage to your equipment.

Temperature Caution!

Be careful when handling the unit. When the unit is plugged in, the internal components generate heat, and consequently the outer casing may feel hot to the touch.

Connecting the Power

The IA261/262 provide 2 kinds of power input, a screw power jack and a 3-pin terminal block, both of which allow 12 to 48 VDC power input. The two power inputs can be used to provide a redundant power solution.

The following figures show how the two power input interfaces connect to external power sources. If the power is properly supplied, the Power LED will light up. The Ready LED will glow a solid green color when the operating system is ready (it may take 30 to 60 seconds for the operating system to boot up).

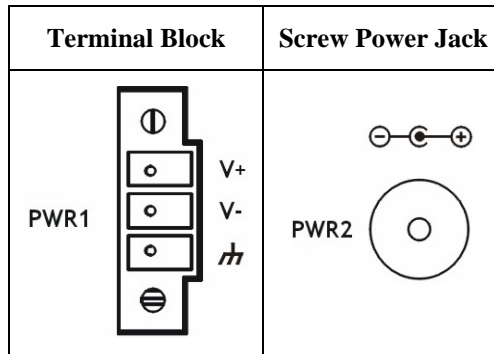

ATTENTION

The power for this product is intended to be supplied by a Listed Power Supply Unit that is rated to deliver 12 to 48 VDC at a minimum of 1200 mA for 12 VDC, and 260 mA for 48 VDC.

Grounding the Unit

Grounding and wire routing helps limit the effects of noise due to electromagnetic interference (EMI). Run the ground connection from the ground screw to the grounding surface prior to connecting devices.



ATTENTION

This product is intended to be mounted to a well-grounded mounting surface, such as a metal panel.

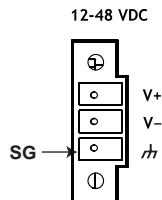

SG: The *Shielded Ground* (sometimes called *Protected Ground*) contact is the bottom contact of the 3-pin power terminal block connector when viewed from the angle shown here. Connect the SG wire to an appropriate grounded metal surface.

Connecting to the Console Port

The IA261/262's console port is a 4-pin pin-header RS-232 port. It is designed for serial console terminals, which are useful for identifying the boot up message, or for debugging when the system cannot boot up.

Serial Console Port & Pinouts

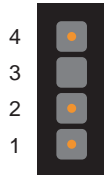

Pin	Signal
1	TxD
2	RxD
3	NC
4	GND

Serial Console Cable



Connecting to a Display

The IA261/262 comes with a D-Sub 15-pin female connector to connect a VGA CRT monitor. To ensure that the monitor image remains clear, be sure to tighten the monitor cable after connecting it to the V481. The pin assignments of the VGA connector are shown below.

DB15 Female Connector	Pin No.	Signal Definition
	1	Red
	2	Green
	3	Blue
	4	---
	5	GND
	6	GND
	7	GND
	8	GND
	9	---
	10	GND
	11	---
	12	---
	13	H-Sync
	14	V-Sync
	15	---

Connecting to a Keyboard and Mouse

Use the 2 USB hosts located at the front side of unit to connect a keyboard and mouse to the IA261/262.

Connecting to the Network

Connect one end of the Ethernet cable to one of the IA261/262's 10/100M Ethernet ports (8-pin RJ45) and the other end of the cable to the Ethernet network. If the cable is properly connected, the IA261/262 will indicate a valid connection to the Ethernet in the following ways:

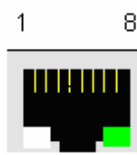

1 8 The LED indicator in the lower right corner glows a solid green color when the cable is properly connected to a 100 Mbps Ethernet network. The LED will flash on and off when Ethernet packets are being transmitted or received.

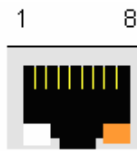

1 8 The LED indicator in the lower left corner glows a solid orange color when the cable is properly connected to a 10 Mbps Ethernet network. The LED will flash on and off when Ethernet packets are being transmitted or received.

Pin	Signal
1	ETx+
2	ETx-
3	ERx+
4	---
5	---
6	ERx-
7	---
8	---

Connecting to a Serial Device

Use properly wired serial cables to connect the IA261/262 to serial devices. The serial ports of the IA261 (P1 to P4) and IA262 (P1 to P2) use male DB9 connectors. The ports can be configured by software for RS-232, RS-422, or 2-wire RS-485. The precise pin assignments are shown in the following table:

DB9 Male Port

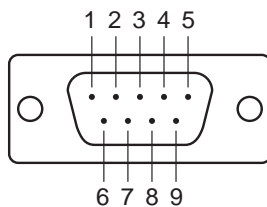

RS-232/422/485 Pinouts

Pin	RS-232	RS-422	RS-485 (4-wire)	RS-485 (2-wire)
1	DCD	TxDA(-)	TxDA(-)	---
2	RxD	TxDB(+)	TxDB(+)	---
3	TxD	RxDB(+)	RxDB(+)	DataB(+)
4	DTR	RxDA(-)	RxDA(-)	DataA(-)
5	GND	GND	GND	GND
6	DSR	---	---	---
7	RTS	---	---	---
8	CTS	---	---	---

Connecting to a CAN Device

The IA262 has 2 CAN ports for connecting CAN devices. The CAN ports of the IA262 (P3 to P4) use male DB9 connectors. The precise pin assignments are shown in the following table:

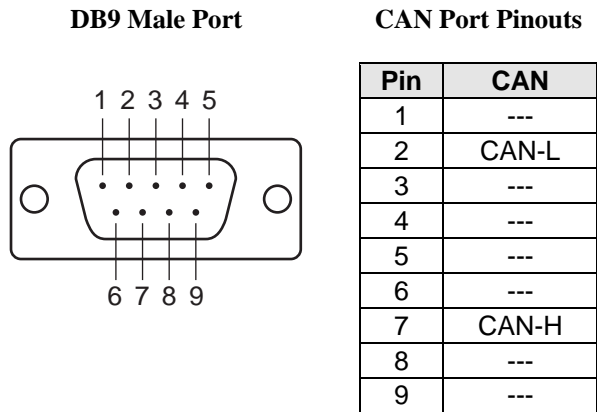

Connecting to the DI/DO

The IA261/262 has an 8-ch digital input and 8-ch digital output, both of which support 3 KV optical isolation protection. The digital input channels and digital output channels are located on the top side of the unit and output by terminal block. The pinouts for the I/O are shown in the figure.

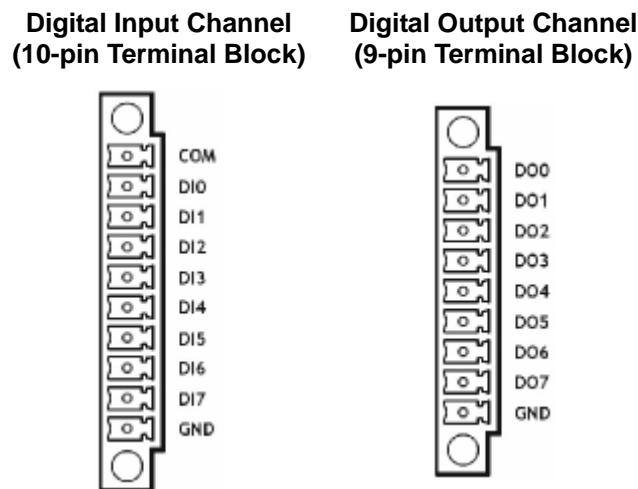

See below for additional wiring instructions.

Digital Input Wiring

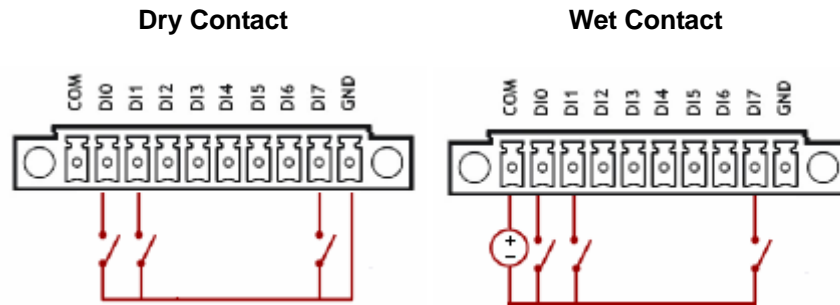

Note: If you are using wet contacts, you must connect “COM” to power.

Digital Output Wiring

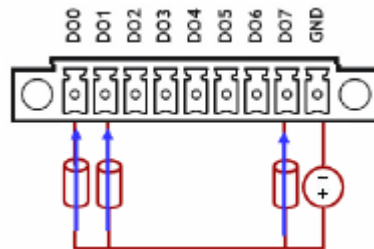

Insert CompactFlash Card

The IA261/262 have a built-in CompactFlash socket. The CompactFlash socket allows users to add additional memory by inserting a CompactFlash memory card, without any risk to the computer.

Follow the instructions below to insert a CompactFlash card:

1. Remove the power source.
2. Unscrew the CompactFlash socket protection cover which is located on the front of the unit.



3. Be sure to insert the CompactFlash card correctly into the protective cover, as shown in the figure below.



4. Insert the CompactFlash protective cover with the CompactFlash card into the socket, as shown in the figure. Be sure to keep the angle vertical relative to the front panel.

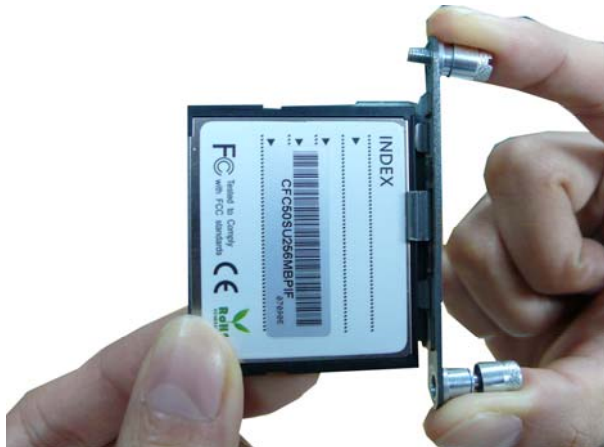

5. Screw the protective cover to the front panel.

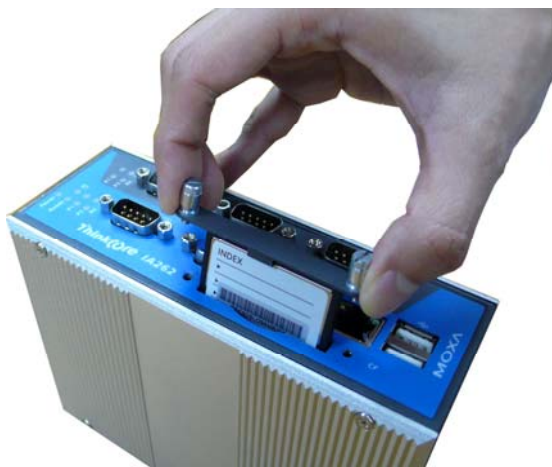

**ATTENTION**

The IA261/262 does not support CompactFlash hot swap and PnP (Plug and Play) function. It is necessary to remove power source first before inserting or removing the CompactFlash card.

USB Hosts

The IA261/262 provides 2 USB 2.0 full speed hosts (OHCI), type A connectors, which support a keyboard or mouse, and as well as an external flash disk for storing large amounts of data.

A

Regulatory Approval Statements



This device complies with part 15 of the FCC Rules. Operation is subject to the following two conditions: (1) This device may not cause harmful interference, and (2) this device must accept any interference received, including interference that may cause undesired operation.

Class A: FCC Warning! This equipment has been tested and found to comply with the limits for a Class A digital device, pursuant to part 15 of the FCC Rules. These limits are designed to provide reasonable protection against harmful interference when the equipment is operated in a commercial environment. This equipment generates, uses, and can radiate radio frequency energy and, if not installed and used in accordance with the instruction manual, may cause harmful interference to radio communications. Operation of this equipment in a residential area is likely to cause harmful interference in which case the user will be required to correct the interference at his own expense.



European Community

Warning:

This is a class A product. In a domestic environment this product may cause radio interference in which case the user may be required to take adequate measures.