

# MES 1215



15" aluminum casing Manufacturing Execution System  
Panel PC Intel Core i processor



## Features

- True flat PCT or 5-wire resistive type touchscreen supported
- Ruggedized IP66 compliant unit
- NANO coating for easy cleaning and maintenance
- Aluminum casing with ventless and fanless design
- Removable SSD
- Chemical treated and strengthen glass touch panel
- Shock tested using Procedure 1G
- Optional - 2nd LAN and wireless LAN

RoHS CE FC

## Introduction

The SENOR MES 1215 is a robust and integrated Manufacturing Execution System with fanless and ventless design specifically developed to be utilized in harsh environments. Featuring operational effective interface, it aims at enhancing work efficiency and offers safe working environments at the forefront. Its whole aluminum die casting case design without button mechanism aids to increase reliability of the unit without compromising on the functionality. Its compact design is compatible with various mounting solutions and is suitable for various industrial applications such as access control and factory automation.

## Specifications

Model No.	MES 1215PC	MES 1215R
CPU	MES 1215VPC / MES 1215VR - Intel Core i3-1215U (10M Cache, up to 4.40 GHz) MES 1215HPC / MES 1215HR - Intel Core i5-1235U (12M Cache, up to 4.40 GHz) MES 1215UPC / MES 1215UR - Intel Core i7-1255U (12M Cache, up to 4.70 GHz)	
System Memory	1*4GB, 2*DDR4 SODIMM sockets, max. 64GB	
TPM	Intel PTT / TPM 2.0	
<b>LCD Touch Panel</b>		
LCD Size, Resolution	15" LED-backlit TFT LCD, 1024x768	
Touch Type	True flat PCT (Projected Capacitive touch)	Resistive Touch
<b>Connectivity</b>		
Storage devices	1*128GB PCIe Gen4x4 NVMe M.2 2280 SSD 1*PCIe Gen4x4 M.2 2280 Expansion Socket, Support RAID 0/1	
Giga LAN	1*RJ-45 (10/100/1000 Mbps)	
USB	2*USB2.0, 4*USB3.0 (1*USB Type C)	
COM port	3*RJ48 (1*RS232, 2*RS232/RS422/RS485)	
External Display	1	
Audio	2*Built-in Speakers, 1*Mic/Line out	
<b>Mechanical &amp; Environment</b>		
Dimensions & Weight	389 * 96 * 334 mm(built-in AC adapter)/ 389 * 67 * 334 mm(external AC adapter), 8 kgs	
Safety Certifications & IP Rating	FCC/CE, IP 66 Compliance	
Storage & Operating Temp.	-20°C ~ 60°C, 0°C ~ 40°C	
Relative Humidity	10% ~ 90% (non-condensing)	
Power Consumption	60 W maximum	
<b>Software</b>		
Operation System support	Windows 10 IoT, Windows 11 IoT	
<b>Peripheral Options</b>		
Wireless LAN	802.11 b/g/n	
2nd LAN (10/100/1000Mbps)	1* Giga LAN	

## Dimensions

Unit: mm

MES 125PC  
389\*67\*334(mm) - External AC adapter

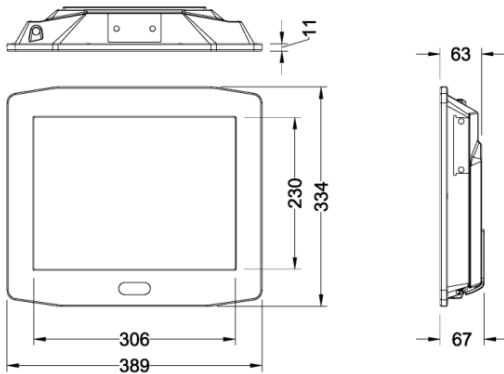

MES 1215PC  
389\*96\*334(mm) - Built-in AC adapter

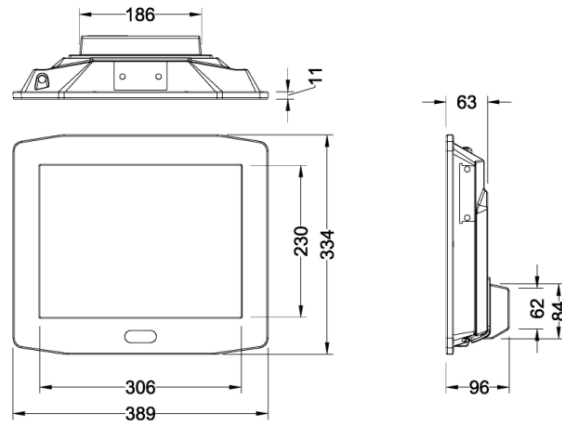

MES 1215R  
389\*67\*334(mm) - External AC adapter

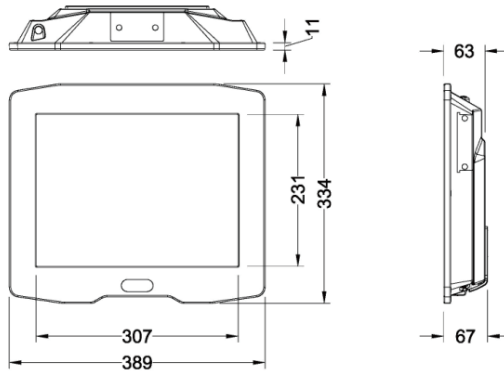

MES 1215R  
389\*96\*334(mm) - Built-in AC adapter

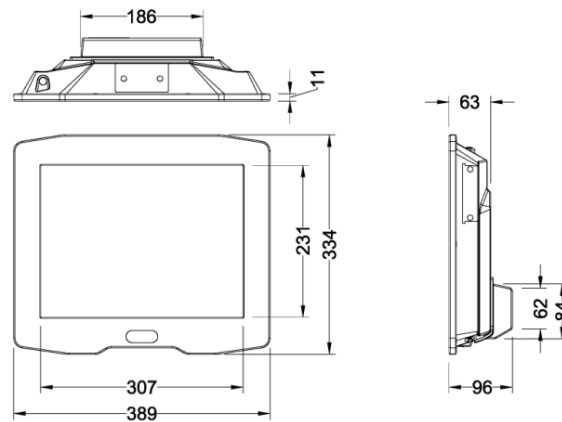

## VESA 75\*75 & 100\*100mm

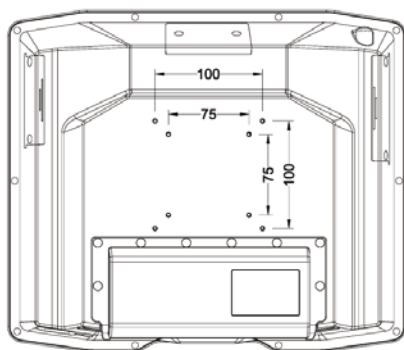

## I/O placement

